

Fission chambers for CANDU[®] SDS neutronic trip applications

Virender (V.K.) Mohindra, Marius Andrei Vartolomei and Alex McDonald

Atomic Energy of Canada Limited
2251 Speakman Drive
Mississauga, ON, L5K 1B2
Canada

Presented at the 28th Annual Canadian Nuclear Society (CNS) Conference
2007 June 03-06, Saint John, New Brunswick, Canada

Abstract

The two CANDU[®] shutdown systems (SDS) use the same type of neutronic instrumentation to monitor the thermal neutron flux and generate the fastest safety trip to terminate the chain reaction, the Log Rate trip. The Log Rate trips on both shutdown systems employ uncompensated ionization chambers. A proven neutronic instrumentation system, which can also be used for Log Rate trips, is also commercially available: the fission chamber based flux-monitoring system. The fission chamber neutron flux-monitoring system is relatively more sensitive to neutrons (leading to a stronger signal), and wider-range (covering the start-up region as well). It is designed to function in high gamma radiation fields and does not need massive lead shielding. This paper discusses the fission chamber based flux monitoring system and provides a comparison with the ion chamber based flux-monitoring system to show that both neutron flux-monitoring systems can perform similar functions. The comparison highlights the unique and salient features of both neutron flux-monitoring systems, with a view towards the option of extending its use for reactor start-ups.

1. Introduction

CANDU[®] reactors use two independent and diverse shutdown systems (SDS), designated as SDS1 and SDS2, to terminate the nuclear chain reaction. Both shutdown systems employ commercially available out-of-core uncompensated ion chambers to measure the thermal neutron flux. The thermal neutron flux at the location of the ion chambers is directly proportional to the fission rate in the reactor core and thus the reactor power. Gamma flux measurement¹ is not a direct measure of reactor power because of the production of gammas by fission products in the fuel and induced radioactivity in the reactor structures.

A proven neutronic instrumentation system, which can also be used for Log Rate trips, is commercially available: the fission chamber based flux-monitoring system. The fission chamber flux monitoring system is relatively more sensitive to neutrons (leading to a stronger signal), and wider-range (covering the start-up region as well). It is designed to function in high gamma radiation fields and does not need massive lead shielding.

¹ Gamma flux measurement on the secondary side is a technique used in other types of reactors.

This paper discusses the fission chamber based flux monitoring system, provides a comparison with the ion chamber based flux-monitoring system to show that both neutron flux-monitoring systems can perform similar functions. The comparison highlights the unique and salient features of both neutron flux-monitoring systems, with a view towards the option of extending its use for reactor start-ups. The theory of operation of the ion chamber and fission chamber based neutron flux monitoring system is well documented in the literature, therefore only a brief description of the principles of their operation is provided.

2. Basic requirements of thermal neutron detectors for trip instrumentation

The basic requirements on the thermal neutron detectors for CANDU[®] SDS Log Rate signal are:

- 1) The neutron detector shall be insensitive to the other nuclear radiation present in the vicinity of the detector;
- 2) The response of the detector shall be proportional to the fission rate in the core;
- 3) The detector shall have a fast response to the changes in the thermal neutron flux in the reactor.

The detection system shall be environmentally qualified (EQ) and seismically qualified (SQ).

The thermal neutron flux of the reactor is monitored through the entire power range, from the source range level to 150% of full power (FP). Two types of instrumentation are used to cover this wide range: in-core and out-of-core instrumentation. The in-core instrumentation is composed of self-powered detectors, together with very small calibrating fission chambers (FC) (~3 mm in diameter). Out-of-core instrumentation is composed of ion chambers, BF₃ and He³ detectors. The instrumentation employed, depending on the power level, is as follows:

- 10⁻¹⁴ to 10⁻⁶ FP: start-up instrumentation, employing in-core BF₃ and out-of-core He³ detectors;
- 10⁻⁷ to ~ 0.15 FP: ion chamber based flux monitoring system;
- Above 0.15 FP: in-core flux detector based flux-monitoring system.

Figure 1 shows the approximate reactor power measurement ranges for the different nuclear instrumentation used in CANDU[®] reactors. The fission chamber based nuclear instrumentation is generally credited with ten to eleven decades of covering range, from 10⁻¹⁰ FP to 150% FP. Coverage of the 10⁻¹⁴ FP to 10⁻¹⁰ FP range is usually achieved by increasing the counting time during approach to criticality or start-up. The fission chamber based flux monitoring system is therefore capable of start-ups from fresh fuel (initial core) conditions and highly gamma active core conditions (e.g. after refurbishment and/or fuel channels replacement).

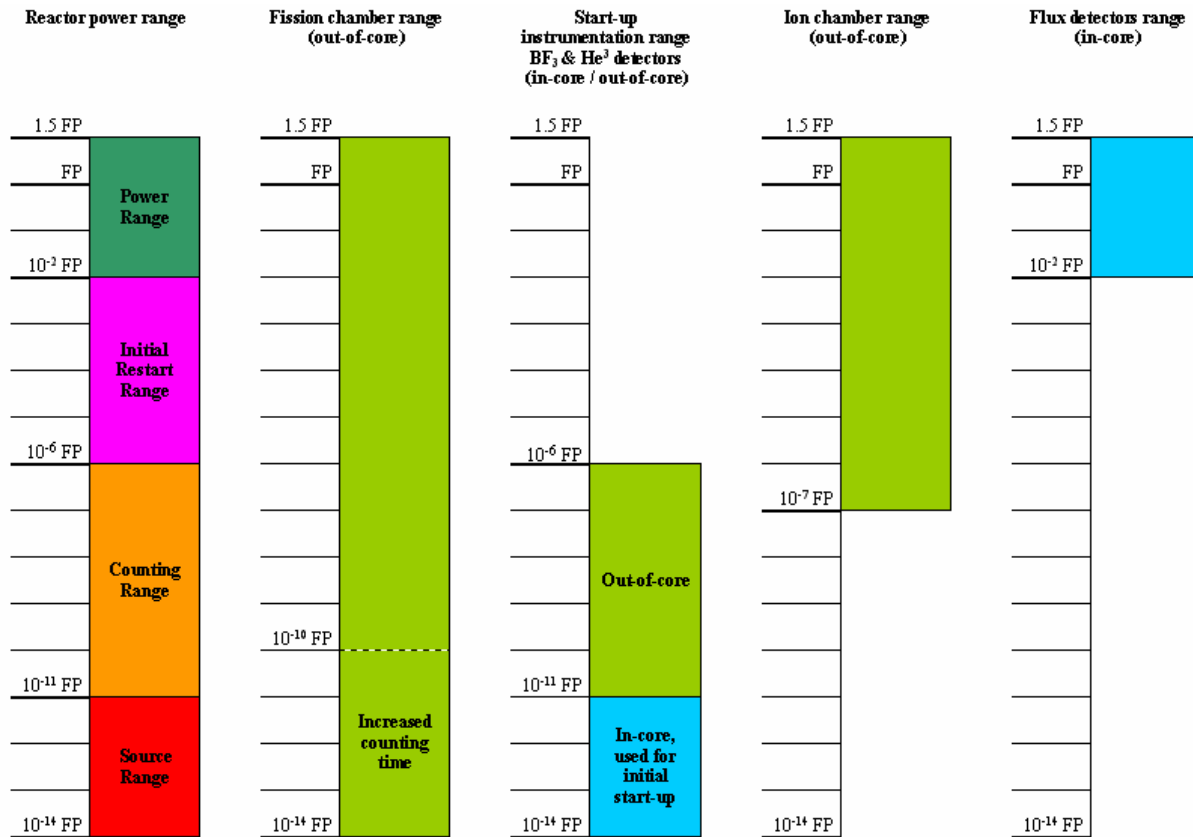

Figure 1 Approximate reactor power measurement ranges for thermal neutron detectors commonly used in a CANDU[®] reactor

3. SDS 1 and SDS 2 ion chamber based flux-monitoring systems

Shutdown systems SDS 1 and SDS 2 are designed to act independently of each other to reduce reactor power. SDS 1 is the primary method of terminating the nuclear chain reaction by inserting thermal neutron absorbing rods into the core when any of the trip parameters exceeds their setpoints. SDS 2 terminates the chain reaction by injecting neutron-absorbing solution (gadolinium nitrate) via a large number of spray nozzles located horizontally at different levels in the reactor core. At present, both systems use out-of-core ion chambers to monitor the thermal neutron flux.

3.1 Ion chamber theory

The electric current response curve of a typical ion chamber (Voltage Bias (V) vs. Current (I)), as shown in Figure 2, has three regions of operation: the recombination, the ionization and the proportional regions. Below about 200 VDC there is not enough voltage bias on the centre electrode to attract the free electrons, thus they recombine with the gas atoms. Between 200 VDC and 1000 VDC, the response becomes almost flat, showing a constant current region of operation. Above about 1000 VDC, free electrons become so energized that they create further ionization in the gas, freeing up more electrons that deposit their charge on the centre electrode. This region produces a current that is approximately proportional to the applied voltage. The ion

chambers are used in the ionization region to achieve a current response that is proportional to the neutron flux. A typical triaxial ion chamber is shown in Figure 3.

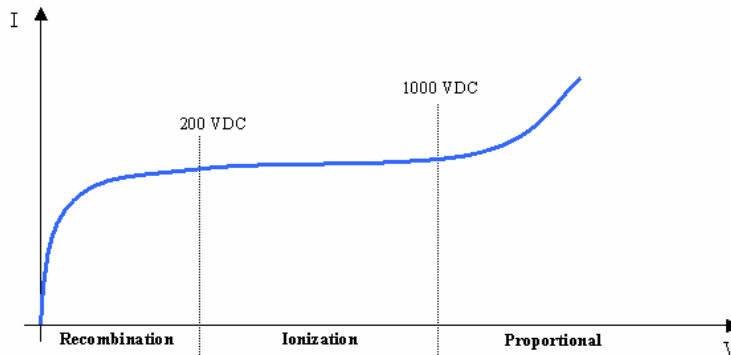

Figure 2 Ion chamber electric current response curve

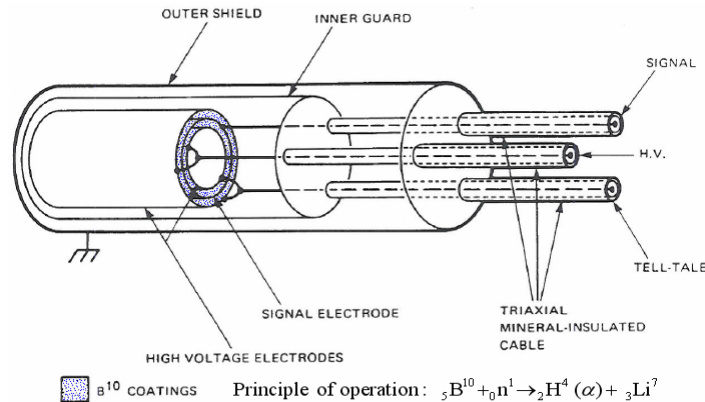

Figure 3 Typical triaxial ion chamber [1]

3.2 Ion chambers in CANDU[®] reactors

The ion chambers are located outside the reactor calandria, and measure the neutrons escaping the reactor. By measuring the thermal neutron flux “N”, the value of “Log N” can be derived. The rate of change of the log N signal, called “Log N Rate” and defined as “ $d(\log N)/dt = 1/N dN/dt$ ” is obtained electronically and used as a measure for tripping the reactor when the rate exceeds a predetermined setpoint. The Log N Rate is measured in percentage per second or decades per second (%/sec or dec/sec). The Log N Rate trip is the fastest trip available in CANDU[®] reactors. The trip is based on the rate of change of the Log N signal and not on the absolute value of the Log N signal.

3.3 Location of ion chambers

The ion chambers for CANDU[®] 6 SDS 1 and SDS 2 are located on the opposite sides of the calandria to achieve 180⁰ separation, as shown in Figure 4.

The SDS 1 ion chambers are located just below the horizontal mid-plane on one side of the reactor while the SDS2 ion chambers are located just above the horizontal mid-plane on the opposite side of the reactor.

3.4 Ion chamber shielding

Ion chambers are located in lead filled steel housing, as shown in Figure 5 and Figure 6, which is designed to attenuate the gamma (γ) dose rate such that the ion chamber response to gamma rays is less than the response to thermal neutrons. This shielding is useful in allowing the ion chambers to remain on-scale due to the photoneutron flux up to about two-months after a shutdown, thus reducing the need to use the start-up instrumentation.

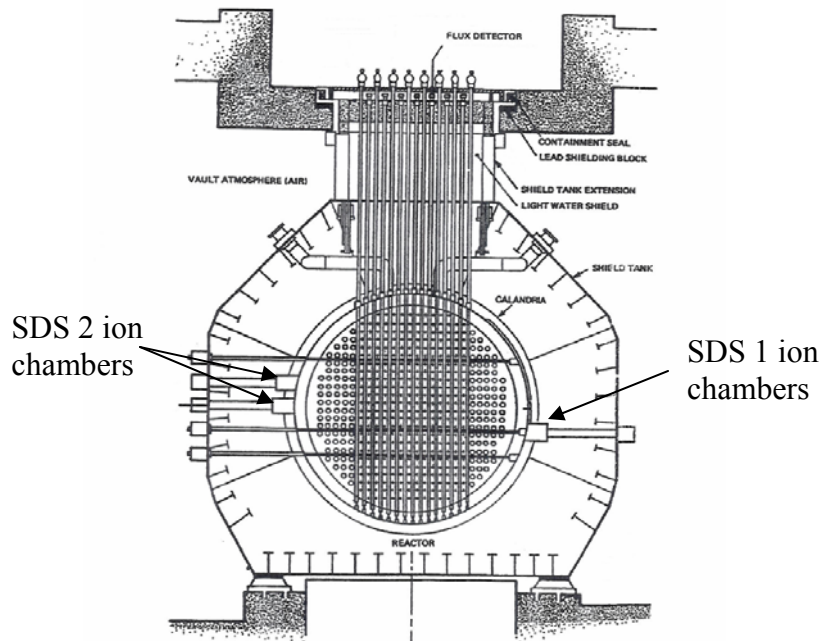

Figure 4 CANDU reactor general assembly [1]

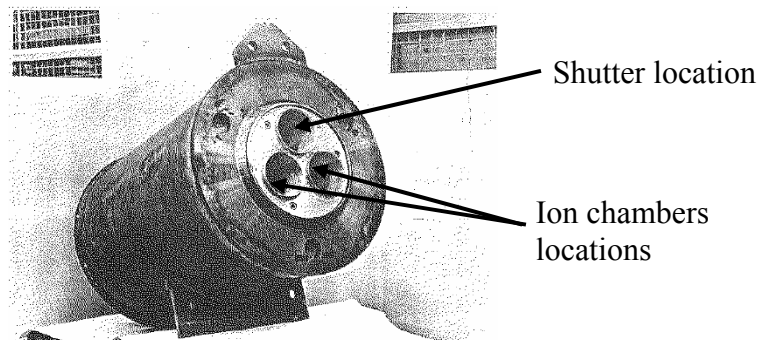

Figure 5 Ion chamber assembly and lead filled housing [1]

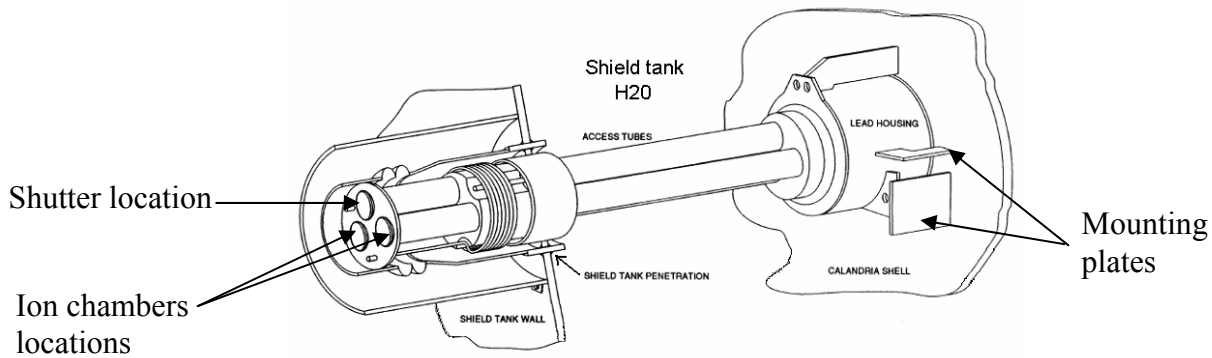

Figure 6 Horizontal ion chamber housing and mounting [1]

3.5 Testing requirements

During normal operation, each safety system trip loop is tested at regular intervals to demonstrate its availability, in order to meet their reliability requirements [2, 5.3.1]. The requirement is to test the loop from the sensing element to the active element (e.g. relay) to initiate a channel trip. A shutter mechanism is used to test the Log Rate trip function of each of the three channels during normal operation. The basic principle of the shutter mechanism is the same for the ion chamber and the fission chamber based Log Rate trip systems. For the ion chamber based flux monitoring system, the test shutter is made of a neutron absorbing material (e.g. cadmium or boron), and is installed in a separate cavity for each ion chamber housing, as shown in Figure 5 above. The movement of the shutter is pneumatically performed at specific rates to cause an increase in thermal neutron flux at the sensitive part of the ion chamber, simulating a positive power excursion rate.

4. Fission chambers

Fission chambers are ion chambers, operating in the ionization region to avoid non-linearities. The fission chamber consists of concentric cylindrical aluminium electrodes with high purity fissile material coating (e.g. Uranium-235), insulators as well as some filling gas (e.g. Argon and/or Nitrogen) as shown in Figure 7.

Similar to the ion chambers, there is no gas amplification in fission chambers. However, fission chambers have the advantage of being useful in a pulse-counting mode because of the relatively large amplitude of each current pulse. In addition, the current pulses due to the interaction of thermal neutrons with Uranium-235 atoms are relatively larger in amplitude than the competing current pulses from other reactions, such as the alpha decay of uranium.

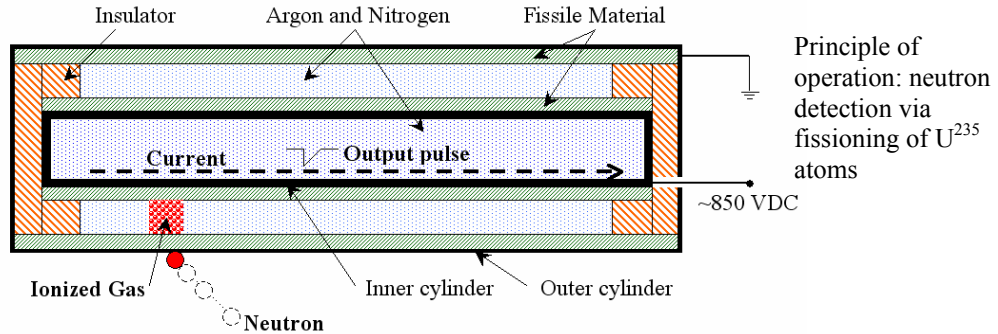

Figure 7 Fission chamber diagram

4.1 Fission chamber flux monitoring system theory

The signal processing electronics for a wide range fission chamber typically operates in two distinct modes:

- 1) Pulse counting mode;
- 2) Mean Square Voltage (MSV) mode, based on Campbell's Theorem [3].

In the pulse counting mode, the current pulses are recorded as discrete events and counted with respect to time. To have an accurate neutron count rate, pulse amplitude discrimination is used to eliminate the unwanted pulses due to alpha decay of uranium and gamma radiation. The energy of uranium fission fragments, originating from thermal neutrons interactions, is typically 165 Mev. The energy of the alpha particles from uranium decay is typically 4.7 Mev, while gamma photons deposit even less energy per interaction.

The pulse counting mode can be used as long as the time interval between two consecutive pulses is long in comparison with the time constant of the measurement circuit. At high-count rates (flux), the pulses start to overlap and the measured count rate will have an error resulting from pulse pile-up. The result is a fluctuating direct current and at this stage the MSV mode can be employed. Based on Campbell's theorem, it can be shown that the mean square variation of the output current is proportional to the neutron count rate, thus the neutron flux. The change from the pulse mode to the MSV mode is done seamlessly by capacitively coupling the fission chamber signal to the input of the pre-amplifier. This action removes the DC component of the signal, resulting in a simplified circuit.

The MSV mode has the advantage of providing a large discrimination against alpha and gamma pulses. This discrimination is required because although the alpha decay count rate is essentially a constant, the gamma flux at low and intermediate power levels is not proportional to the neutron flux. Because the total output signal of the detector is the sum of the neutron and gamma signals, the gamma error can be expressed as the ratio of the square of the gamma signal to the square of the neutron signal. By removing the DC component and operating in Campbell mode, the gamma contribution is typically three orders of magnitude less than if the same fission chamber was operated in the DC mode.

4.2 Location of the fission chambers

The fission chambers do not require any lead shielding. The mechanics of mounting a fission chamber is considered simpler than that of an ion chamber. Figure 8 shows a possible installation of a seismically qualified fission chamber assembly. By using a cantilever system, there is no need for mounting supports welded to the calandria shell.

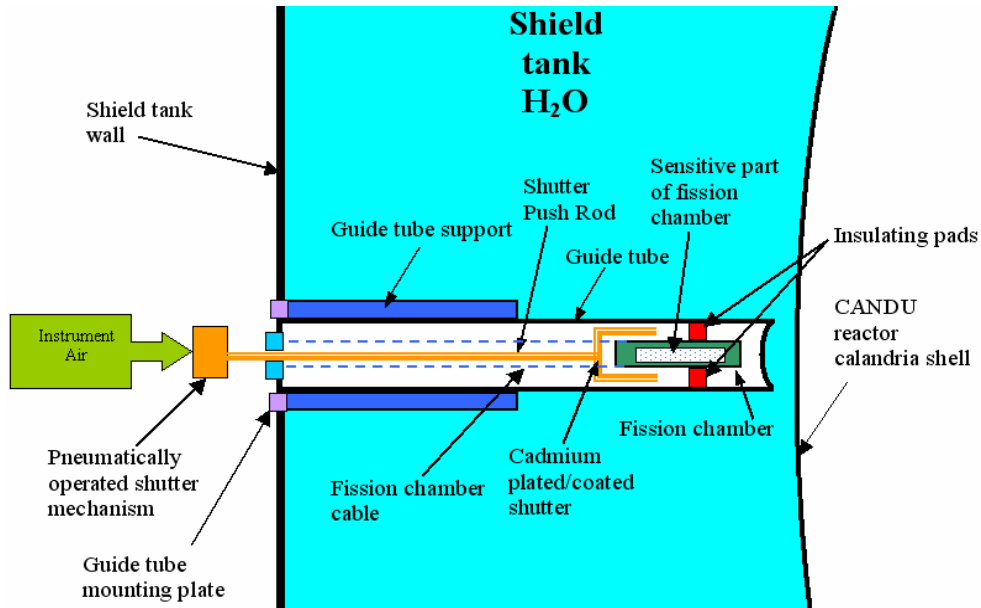

Figure 8 Conceptual installation of a fission chamber

4.3 Fission chamber test shutter mechanism

In normal operating conditions, the neutron-absorbing shutter covers part of the sensitive length of the fission chamber. The withdrawal of the shutter results in an increase in the thermal neutron flux at the location of the sensitive area of the fission chamber. The shutter cylinder is located concentrically over the sensitive part of the fission chamber, which would allow the fission chamber based flux monitoring system to be more compact than the ion chamber based flux monitoring system. The shutter is a metallic cylinder coated or plated with cadmium or any other suitable thermal neutron absorbing material. The movement of the shutter is pneumatically performed via a push rod attached to the shutter cylinder as shown in Figure 8.

5. Use of fission chamber based flux monitoring systems in nuclear reactors

Fission chambers are widely used for control and monitoring purposes in Pressurized Water Reactors (PWR), Boiling Water Reactors (BWR) and Pebble Bed Modular Reactors (PBMR) around the world. Pressurized Heavy Water Reactors (PHWR) CANDU[®] Pickering A reactors use fission chambers for reactor tripping function and for monitoring reactor power on a continuous basis. Fission chambers are also used in Test Research and Training Reactors

(TRTR) and MMIR (MDS Nordion Medical Isotopes Reactor) reactors at AECL’s Chalk River Laboratories.

6. Use of fission chamber based flux monitoring system for refurbished CANDU® reactors start-up

Normal in-core start-up instrumentation, based on BF₃ neutron counters, can’t be used for CANDU® reactors after refurbishment and/or fuel channels replacement: the gamma radiation fields inside the calandria, resulting from induced gamma activity in the calandria and its structures, are very high. Therefore, after extensive considerations, including the past experience with fission chambers at Pickering NGS, a fission based start-up instrumentation design was adopted. The fission chambers will be located inside a guide tube installed through one of the view ports. The range monitored will be from 10⁻¹⁴ FP to 10⁻⁶ FP. To improve the statistical variation below 10⁻¹⁰ FP, the neutron counting time will be increased.

7. Comparison of ion chamber and fission chamber flux monitoring systems

Table 1 compares the salient features of the ion chamber and the fission chamber based flux-monitoring systems.

Table 1 Comparison of ion chamber and fission chamber based flux monitoring systems

Characteristics	Ion chamber based flux monitoring system	Fission chamber based flux monitoring system
Principle of operation	(n,α) reaction with B ¹⁰	Neutron induced fission of enriched U ²³⁵
Output signal	Log N signal output proportional to the logarithm of the signal over a range 10 ⁻⁷ FP to 150 % FP.	Log N signal output proportional to the logarithm of the signal over the potential range of 10 ⁻¹⁰ FP to 150 % FP. Coverage from 10 ⁻¹⁴ FP to 10 ⁻¹⁰ FP is usually achieved by increasing the counting time. In Pickering A, the FCs are designed to be used over a range of eight decades.
Signal sensitivity	Signal is sensitive to thermal neutrons and gamma rays.	Designed to be sensitive to thermal neutrons and operate in high gamma radiation fields.
Sensitivity lifespan	Small decrease of sensitivity over time. Have operated satisfactorily for up to 25 years in more than 30 CANDU® reactors with no significant impact on performance.	Maintains specified performance and very small decrease in sensitivity over 40 years, through proper selection of the coating material, which is made up of fissile plus fertile material.

Cable configuration	Signal cables have a coaxial arrangement	Signal cables have a continuous floating tri-axial arrangement.
Post-accident application	Gamma radiation at low power levels complicates monitoring.	Designed to meet post-accident conditions.
Start-up application	Can only be used above 10^{-7} FP.	Provides monitoring for: 1) Start-up from fresh fuel – initial core condition. 2) Start-up after fuel channels replacement / refurbishment.
Inherent discrimination feature	Needs a lead shield to shield against gamma radiation.	1) In the counting mode, pulse amplitude discrimination is used. 2) In MSV mode, provides large amount of inherent discrimination against alpha and gamma pulses.
Shutter design	Shutter occupies a separate cavity in the lead shielding	Shutter is concentric around the fission chamber and needs less space

The comparison shows that fission chamber based flux monitoring system can accommodate well to the full life of the reactor, including refurbishment (i.e. the irradiated and highly gamma active core conditions).

The detailed economic comparison of the two systems needs to be done to show that the fission chamber system has an economic advantage for CANDU[®] reactors. The fission chamber based system is a permanently installed system, as compared to the installation and removal of the start-up instrumentation system before and after maintenance outages, which could save appreciable critical path time and excessive operators effort.

8. Conclusion

Ion chamber and fission chamber based neutron flux monitoring instrumentation are a proven technology, with many years of operating experience in different types of reactors around the world, including Pickering A CANDU[®] reactors. Due to the high gamma flux in reactors after refurbishment, the fission chamber based flux-monitoring system for start-up, control and trip functions is a viable option. Wide range fission chamber based flux monitoring systems provide the unique advantage of being able to cover up to fourteen decades of reactor power, thus eliminating the need for separate start-up instrumentation.

References

- [1] Figures are based from CANDU[®] 6 generic design documents and were modified to suit this paper's requirements.
- [2] Atomic Energy Control Board (now CNSC), R-8 "Requirements for Shutdown Systems for CANDU Nuclear Power Plants" Effective date: February 21, 1991.
- [3] Glenn F. Knoll, "Radiation detection and measurement", *John Wiley and Sons*, Third edition, 2000.

Acknowledgment

The authors would like to thank Clark J. Artaud, from Thermo Fisher Scientific, for the helpful discussions.